

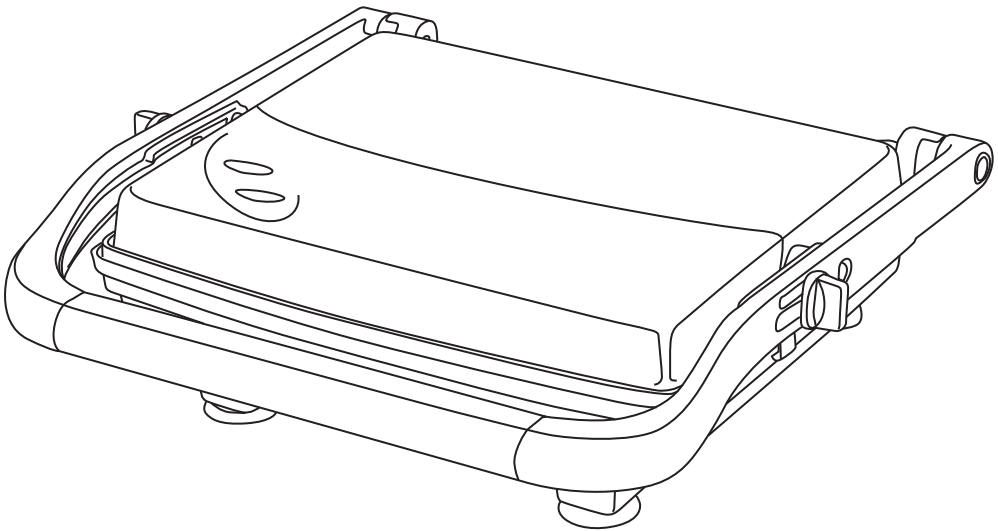

# mellerware®

E X E C U T I V E

P a n i n i M u l t i - G r i l l



complies with  
INTERNATIONAL  
IEC60335  
SAFETY SPECIFICATIONS



Model:  
28500

**PLEASE READ ALL INSTRUCTIONS BEFORE USE**

**2 year guarantee**



## IMPORTANT SAFETY INSTRUCTIONS

When using an electrical appliance, basic safety precautions should always be followed, including the following:

### PLEASE READ ALL INSTRUCTIONS BEFORE USE AND SAVE FOR FUTURE REFERENCE

- 1) To protect against electrical shock, do not immerse any part of the appliance or cord into water or any other liquid.
- 2) Do not touch hot surfaces. Use handles or knobs.
- 3) Close supervision is necessary when the appliance is used by, or near children.
- 4) Do not leave the appliance unattended when not in use.
- 5) Always use the appliance on a dry and stable work surface.
- 6) Do not use this appliance outdoors.
- 7) Always unplug the appliance from the power outlet socket when not in use and before cleaning.
- 8) Do not operate the appliance if damaged, or after it malfunctions. If the appliance is damaged or malfunctions in any manner, return it to the approved service agent for service or repair to avoid any hazard.
- 9) In the interest of safety, regular periodic close checks should be carried out on the supply cord to ensure no damage is evident. Should there be any signs that the cord is damaged, return the appliance to the approved service agent for service or repair.
- 10) Do not let the cord hang over the edge of the table or work surface, or touch any hot surfaces. Allow the appliance to cool before wrapping cord in cord storage where applicable.
- 11) Care must be taken not to touch any hot surfaces, do not store or cover the appliance until it has fully cooled down.
- 12) Do not place the appliance on or near a hot gas or electric burner, in or where it could touch a heated oven or microwave oven.
- 13) Do not use harsh abrasives, caustic cleaners or oven cleaners when cleaning this appliance.
- 14) CAUTION: When using this appliance, allow adequate air space above and on all sides for circulation. Keep the appliance away from curtains, dishtowels, wall coverings or any other flammable materials during use. Caution is required on surfaces where heat may cause a problem.
- 15) **THIS APPLIANCE IS FOR HOUSEHOLD USE ONLY. DO NOT USE THE APPLIANCE FOR ANYTHING OTHER THAN ITS INTENDED USE.**

## CHARACTERISTICS

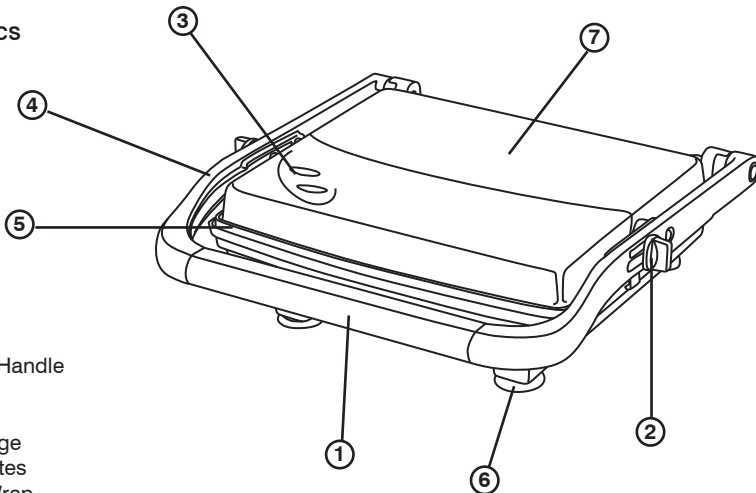

1. Cool Touch Handle
2. Handle Clip
3. Ready Light
4. Floating Hinge
5. Cooking Plates
6. Feet/Cord Wrap
7. Housing



## OPERATING INSTRUCTIONS

### Before Use

Before using your multi-grill press for the first time, the non-stick cooking plates must be seasoned. Plug the power cord into a 230-240 volt AC mains power supply outlet. Turn the temperature control knob to a mild setting to pre-heat the unit until the ready light illuminates.

Wipe a small amount of butter onto the plates and using a soft cloth or grease proof paper, rub lightly over the plates. Wipe away any excess.

**NOTE: When using your grill press for the first time, you may notice a fine smoke haze being emitted from the unit. This is normal. It is due to the initial heating of internal components.**

### Using your Multi-Grill Press

Your Multi-Grill Press can be used to grill sandwiches, panini, red meat, chicken breasts, sausages, fish, and vegetables.

1. Plug the power supply cord into a 230-240 volt AC power outlet and switch "ON".
2. Pre-heat the unit until the Ready Light illuminates.
3. Once you have prepared your food, place it onto the cooking plates.
4. Gently lower the lid by pulling down the cast metal arms. The floating hinge system will adjust automatically ensuring that the top cooking plate lies evenly on your food, for perfect cooking every time.

**NOTE: Ensure that the cord is kept well away from the cooking plates when in use.**

5. Grill/toasting time will depend on your personal taste. As both sides are cooked at the same time toasting or grilling time is reduced.
6. The cooking plates are coated with a durable non-stick coating. Some fillings (e.g. cheese) may melt and cause food to stick to the plates. Never use a sharp or metal object when removing food from the Cooking Plates as these will damage the non-stick surface. Use a plastic spatula or wooden spoon.

**Note: The 'Ready' light is thermostatically controlled and will cycle during cooking to ensure that the temperature is maintained.**

7. You can adapt toasting time to your taste. The time required depends on the kind of food (e.g. meat - its thickness and its original temperature.) and your personal taste.
8. After you have completed using your Multi-Grill Press, pull the plug out from the wall socket. Keep the unit open to allow it to cool. Wipe it clean using a soft damp cloth and/or paper kitchen towel.

### Hints for best results

1. Breads with a high sugar content (fruit loaf, etc) will toast more quickly than plain sandwich breads.
2. Any type of bread can be used, white, wholemeal or wholegrain.
3. For sweet snacks, sprinkle castor sugar over the buttered sides of the bread.
4. When using raisin bread, brioche or other sweet breads that contain high sugar content, keep in mind that they will brown much more quickly than other breads.
5. For a wholesome meal, large pieces of focaccia bread may be toasted with desired filling.
6. Bread rolls may also be toasted with desired filling.
7. For a light snack savory or sweet bagels may be toasted with desired filling.
8. Be careful when biting into sandwiches containing fillings such as cheese, tomato or jam as they retain heat and can burn if eaten too quickly.
9. It is not necessary to butter the outside of all breads as the appliance has non-stick cooking plates. However, to encourage even browning of bread or when using stale bread, spreading with a small amount of butter is recommended.
10. When using marinades etc, brush the cooking plates with butter or vegetable oil before grilling.

## CARE AND CLEANING

### Non-stick Coating

When cleaning the non-stick coating, do not use metal (or other abrasive) scourers. After cleaning, dry the Multi-Grill Press and lid thoroughly with a soft cloth before storing. Always REMOVE the plug from the power point after use and before cleaning. The cooking plates are coated with a non-stick surface and therefore little cleaning is required. Once cooled, simply wipe the cooking plates with a dampened cloth.

**Do not immerse your Multi-Grill Press in water or any other liquid. Do not use abrasive scouring pads or powders.**

**Do not place your Multi-Grill Press in a dishwasher.**

### To clean the exterior

Simply wipe over with a dampened cloth and polish dry with a dry soft cloth. Do not use steel wool, scouring pads or abrasive cleaners as these will damage the surface.

### Storage

Your Multi-Grill Press will store in an upright position in cupboards, shelves or on the bench top. Simply bring the plates together and, press the securing latch located on the right cast metal arm. This will lock the plates together. Wind the cord around the storage area provided.





creative housewares

27 Nourse Avenue Epping 2 Cape Town  
P.O. Box 975 Eppindust 7475 South Africa  
Tel: +27 21 534 8114 Fax: +27 21 534 8086  
Service Centre Share Call: 086 111 5006  
web: [www.creativehousewares.co.za](http://www.creativehousewares.co.za)

